



GA-171 Gas Detector

Operation and Maintenance Manual

GA-171 Gas Detector Operation Manual

Table of Contents

I. Configuration & Parameters	
a. Entering Setup.....	3
b. Configure Each Channel	3
c. Calibration.....	4
II. Operation	
a. Start up and Installation	5
b. Operation Screens	5
c. Acknowledgment of Alarms	5
Appendix A	7
Appendix B	7
Drawings	
Circuit Board.....	6
Wiring Diagram	8
Alarm Relay Wiring.....	9

I. CONFIGURATION OF PARAMETERS

Configuration of Sensor Parameters & Calibration of Sensors

Each GA-171 Gas Detector will be set up from the factory as per the ordering instructions. However, settings and sensors can be changed using the following procedure.

A. Entering Setup: All parameters are set in the password protected setup section.

1. Press the \downarrow key until the password screen is reached.
2. Use the \oplus and \ominus keys to set the password. The password is "171".
3. Press the \downarrow key.

B. Configure Each Channel

The selected channel will flash. Move between the channels with the \uparrow and \downarrow keys. When the desired channel is flashing, press the \oplus key to enter setup for that channel. Setup for each channel is identical.

1. **SPAN:** This parameter should be set to match the sensors full scale. (Example: If the sensor has a 0-10 PPM range than this parameter must be set to 10 PPM. If it does not match the sensor than it will not display a proper output.)

PRESS \downarrow TO GO TO THE NEXT PARAMETER

2. **GAS TYPE:** This parameter adjusts the gas type to be displayed for this sensor. You can toggle through the list of gases using the \oplus and \ominus keys. *NOTE: The gas type must match what the sensor was designed to detect.*

PRESS \downarrow TO GO TO THE NEXT PARAMETER

3. **ALARM:** This parameter represents the critical level for the detected gas. The GA-171 will be factory set at recommended alarm levels. To adjust this parameter use the \oplus and \ominus keys.

PRESS \downarrow TO GO TO THE NEXT PARAMETER

4. **MODE:** The channel can be set to latching or non-latching. Selection is changed using the \oplus and \ominus keys. *NOTE: This refers to the ALARM level. If an alarm state is reached while in the latching mode the user must acknowledge the alarm by pressing the \ominus key regardless if the alarm condition has changed.*

PRESS \downarrow TO GO TO THE NEXT PARAMETER

5. **DELAY:** This parameter allows for a delay in response to the alarm. The recommended setting is between 5 & 30 seconds. During this delay time the GA-171 will not respond to any detected gas level. However, if an alarm detection level remains present after this delay time than the alarm will activate immediately. *NOTE: Increasing the delay time may help to avoid false alarms caused by transient effects.*

PRESS \downarrow TO BEGIN THE CALIBRATION

C. Calibration

The GA-171 comes calibrated from the factory, but should you need to calibrate it you can do so two different ways.

SPAN GAS

1. Zero Cal the GA-171 when satisfied that the sensor is not picking up any trace of gas or false reading from transient effects.
2. Span Cal the GA-171 with test gas of a 25% to 75% concentration of the span amount.
3. Connect the test flow tubing to one port on the GA-171 gas sensor cap. The ports allow for insertion into flexible plastic tubing and must be inserted with a tight seal for accurate results. Be sure that both port caps are removed.
4. Flow the test gas at 500cc/min for approximately one to two minutes.

ELECTRICAL CALIBRATION

1. Disconnect the sensor.
2. Connect a signal generator to the corresponding leads of the sensor you wish to calibrate.
3. Input a 4mA signal for the Zero Cal.
4. Input a 20mA signal for the span Cal.



II. Operation of the GA-171

A. Start Up and Installation

1. When connecting A/C power to the instrument, it is imperative that the A/C source be well grounded. Insufficient A/C grounding will disrupt proper operation of the instrument.
2. **Initial Power Up:** Each time the GA-171 power is turned on the alarms will be inactive for five minutes. A countdown will be shown on the display. This allows for the sensor(s) to stabilize.
3. **Gas Density:** For measured gases that are heavier than air, the GA-171 gas sensor should be mounted 12" to 24" from the floor (Example: Chlorine & Sulfur Dioxide). For measured gases that are lighter than air, the GA-171 sensor should be mounted 12" to 24" from the ceiling.
4. **Sensor Protection:** The sensor should not be exposed directly to extreme temperatures and/or conditions and should be protected with a rain shield if mounted outside. If water or debris builds up on the sensor its performance will be compromised.
5. **Sensor Start Up:** The large sensor cap must be removed upon start up. The cap is used to protect the sensor during shipment and storage and the two ports on it are to be used for calibration with test gas.
6. **Weekly Checks:** It is recommended that the GA-171 Gas Alarm be exposed to a small amount of the measured gas each week in order to test the reaction of the sensor.
7. **Calibration:** It is recommended that calibration be carried out in approximately six (6) month intervals. Be sure to retain the sensor cap for these periodic calibrations.
8. **LED Indicators:** The alarm indicator LED on the front panel will illuminate as long as an alarm condition is present.

B. Operation Screens

This section explains the features of the standard operating screens of the GA-171.

NOTE: Navigate between the display screens below using the  and  keys.

1. **Home Screen:** This screen displays the gas type and reading of the sensor(s).
2. **Status Screen:** This screen shows all present alarm conditions.
3. **Password Screen:** See Section I.A for instructions on this screen and the configuration section.

C. Acknowledgement of Alarms

If an alarm condition occurs, the alarm (red) LED will illuminate. To acknowledge an alarm press the  key.

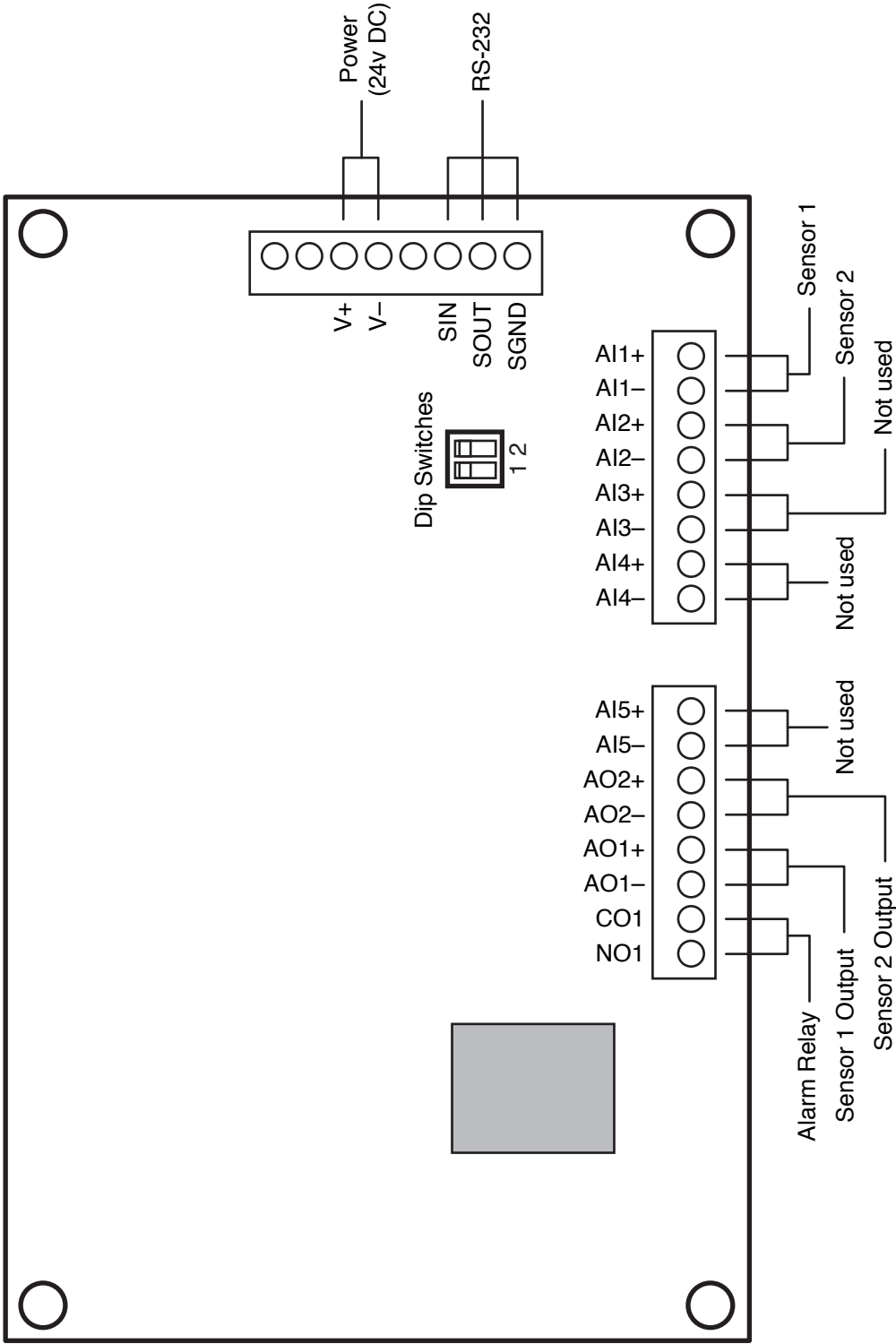

GA-171 GAS LEAK DETECTOR Date: April 2007
CIRCUIT BOARD Dwg. No. GA171-PCB-1

APPENDIX A

Span Calibration Procedure with Test Gas

Required Equipment

1. The test gas should have a concentration of between 25% and 75% of the sensor span amount of the desired gas in a neutral buffer (typically Nitrogen would be the buffer gas).
2. Obtain and connect a regulating system to meter the test gas flow at a controlled rate of 500 cc/min.

Procedure: Refer to Section I.C SPAN GAS.

1. Connect the test gas flow tubing to one port of the Hydro Model GA-171 gas sensor cap. The ports allow for insertion into flexible plastic tubing and must be inserted with a tight seal for accurate results. Be sure that both port caps are removed.
2. Turn on the test gas flow at 500 cc/min and allow it to flow for approximately 1 to 2 minutes, until the reading on the monitor stabilizes.
3. When the reading has stabilized and while the gas is still flowing across the sensor, adjust the display reading with the ⊕ and ⊖ keys until the correct value is indicated on the monitor. (Example: for a test gas of 5 PPM the reading may stabilize at 4.8 PPM, you would then press the ⊕ key (do not hold down the key) until the display indicates 5 PPM.)

Alternate Calibration Procedure

The above method adjusts the zero and span settings inside the monitor electronics. The sensor/transmitter is also set up to allow zero and span settings to be adjusted. This other method involves adjusting potentiometers on the transmitter board inside the sensor housing. Hydro Instruments recommends that the above procedure be used instead, but if it is desired or necessary to calibrate at the sensor/transmitter, then please contact the factory for further information.

APPENDIX B

Electrical Calibration Connections

NOTE: This section relates to electrical calibration of the sensor inputs on the monitor of the GA-171 Gas Detector. This section does not relate to calibration of the sensors.

Required Equipment

1. An accurate current signal generator to provide a calibrated 4-20 mA signal.

Procedure: Refer to Section I.C ELECTRICAL CALIBRATION.

1. Disconnect the sensor from the monitor connections for the channel to be calibrated.
2. Connect the positive lead of the current source to the positive input of the channel to be calibrated. Connect the negative lead of the current source to the negative input.
3. Set the current source to 4 mA and adjust the monitor display with the ⊕ and ⊖ keys until zero is indicated on the display. Depress and release the keys. Do not hold down.

- Set the current source to 20 mA and adjust the monitor display with the \oplus and \ominus keys until the sensor span value of 100% is indicated on the display (i.e. for a 0-10 PPM sensor the display should indicate 10 PPM, 100%).

NOTE: The current source can also be set to any other value between 4 mA & 20 mA and the display can be set accordingly. The GA-171 will then linearly interpolate a straight line between the zero point and this second calibration point to obtain the Current/Concentration curve.

NOTES: Channel connection terminals.

- Sensor 1: Positive = Sensor 1+, Negative = Sensor 1-. *Sensor 2: Positive = Sensor 2+, Negative = Sensor 2-.
- 24V: 24 Volt Power Supply for sensors only (100 mA maximum current)

**These will not be used on a single sensor unit. Only applies to units with two (2) sensors.*

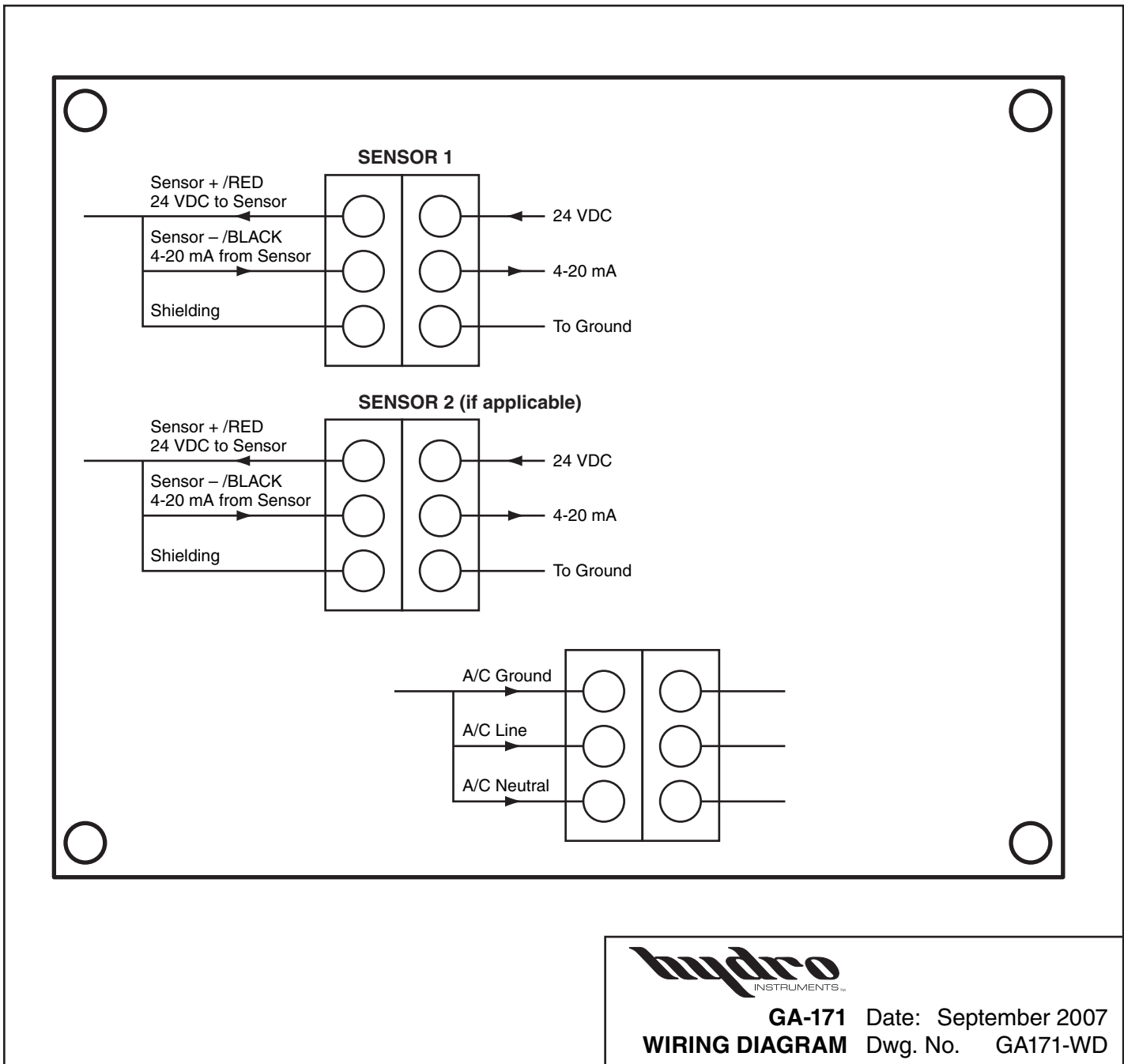

hydro
INSTRUMENTS

GA-171 Date: September 2007
WIRING DIAGRAM Dwg. No. GA171-WD

ALARM RELAY WIRING

The illustration at right depicts the basic wiring diagram of how to wire a Hydro Instruments Gas Alarm relay to a device requiring a 120v or 240v power source.

The Gas Alarm relays are not a powered relay. To power a component attached to the Gas Alarms relay you must provide an external power source. Typically this is done by connecting one lead of the power source to the component and the other to the CO (common) terminal of the relay. Complete the circuit by connecting either the NO (normally open) or NC (normally closed) terminal to the device depending on how you want your device to operate.

Either the line or neutral leg of the AC power can be wired through the relay.

Example

